

DIVIDERS

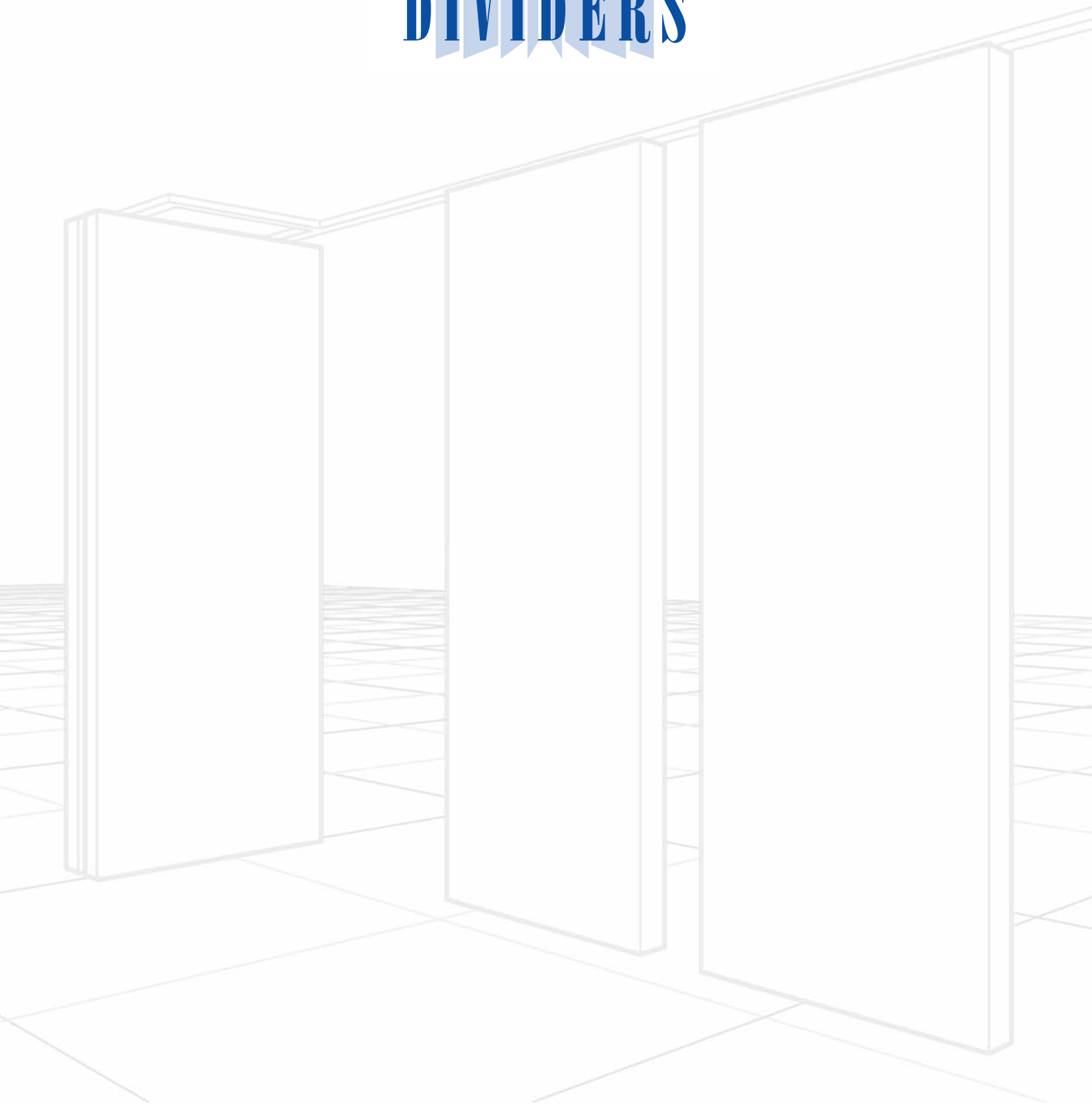

Dividers Modernfold Limited



Flexible & versatile
space management solutions



Contents

The Range 4

Product Selector

Operable Walls 7

Series 85, 100 & 110

Operable Walls 8

Technical Specification

Folding Walls 9

Sesam Vikett Series 65 & 85

Folding Walls 10

Technical Specification

Expanding Walls 13

Concertina 800, 801 & 160

Expanding Walls 14

Technical Specification

Folding Walls 16

Uno & Duplo

Glass Partitions 18

Type GM



2008

The AIS Contractors award is presented annually to promote and encourage high levels of craftsmanship

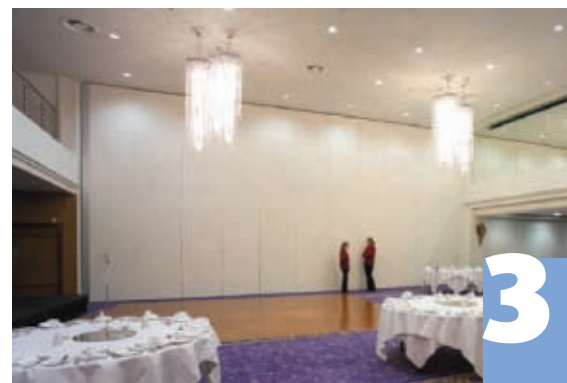

Dividers

Creative Flexibility

The effective division of space sometimes requires utmost flexibility. Whether the requirement is to divide a teaching area, temporarily partition a conference suite, or simply create extra rooms out of one large space, the answer is – movable walls.

Movable walls, operable walls, sliding folding partitions - this group of products is synonymous with one name; Dividers.

Part of the Envirohold Group of companies, Dividers is one of Europe's leading manufacturers of movable wall systems.

Dividers provides unrivalled experience in the design and manufacture of space utilisation products.

Alongside Dividers operable walls, the Envirohold family of products also include, Sesam hinged partitions and Modernfold concertina partitions, along with a range of glass movable walls and industrial doors.

This comprehensive range of movable wall and door systems are manufactured at the group's three European plants based in the UK and Sweden.

Whether your essential requirement is sound attenuation, ease of operation, or aesthetics, there is a solution in the Envirohold family of movable wall companies.



Product Selector

	Acoustic Rating <i>dB (Rw)</i>	Acoustic Rating <i>STC</i>	Thickness (mm)	Weight <i>kg/m²</i>	Max Panel Height mm	Max Opening Width	Panel Widths mm	Panel Construction / Frame	Panel Construction / Seal	Track System / Floor	Track System / Ceiling
OPERABLE WALLS Series 85/100/110											
Type 85	37/42	37/43	85	35/43	6000	Any	600-1250	Alu	Operable	Particle Board	- •
Type 100	39/46/50	47/53	100	45/55	Any	Any	600-1250	Alu	Operable	Particle Board	- •
Type 110	37/41/45 50/53	37/55	110	36/55	Any	Any	600-1250	Alu/Steel	Operable	Particle Board	- •

FOLDING WALLS SESAM VIKETT

Type 65	30/38/41 42/43	-	65	35/40	4000	Any	450-900	Timber	Fixed	Particle Board	• -
Type 85	30/38/41 44/46/49	-	85	25/45	5000	Any	450-900	Alu	Fixed	Particle Board	• •

EXPANDING WALLS

800 Series	-	-	145-220	8	5000	Any	-	Steel	Fixed	Vinyl/Carpet	- •
801 Series	18.4	-	145-220	10	5000	Any	-	Steel	Fixed	Vinyl/Carpet	- •
160 Series	31.2	-	145-220	26	5000	Any	-	Steel	Fixed	Vinyl/Carpet	- •
Uno	28	-	12	15/20	3300	Any	150-296	Timber	Fixed	Particle Board	- •
Duplo	41/43	-	12	36/40	4000	Any	142-294	Timber	Fixed	Particle Board	- •

GLASS PARTITION

Type GM	-	-	12-44	43	3500	Any	Max 1200	Alu	Fixed	Glass	• •
---------	---	---	-------	----	------	-----	----------	-----	-------	-------	-----

The above information is for guidance only. Further technical details are available from our technical services department.

Acoustic Ratings

APPLICATION	CERTIFIED DB REDUCTION	PRODUCT TYPE
Conference centres, offices and hotels requiring full confidentiality	50+	Dividers 100/110
Hotels, offices and education	45	Dividers 85/100/110 Sesam 85
Education and Training	40	Sesam 65/85 Dividers 85/100 Duplo
Leisure and Sport, education	35	Dividers 85/100 Sesam 65/85
Community centres and primary schools	30	801/Uno



Key Features & Benefits

- Individual panels that can be stored away for maximum space utilisation
- Operable top and bottom seals for effortless operation
- Isolated aluminium frame construction for enhanced acoustics
- High performance multiple infills for maximum sound attenuation
- Unique track and carrier system ensuring quiet and easy operation
- Numerous panel stacking options for complete flexibility
- No floor track ensuring obstruction free threshold
- Three panel sizes to accommodate a wide range of acoustic requirements
- Extensive range of surface finishes can be applied

Operable Walls

Series 85, 100 & 110

Dividers

The operable wall series is the highest specification range of fully operable, individual-panel partition system. Acoustic insulation of up to 53dB noise reduction is achieved with a combination of operable top and bottom seals, high performance multiple infills and a panel assembly design that allows an acoustic break between the frame and outer layer.

The vertical channels of each panel incorporate polymer inserts that facilitate an acoustic seal when the panels are set out as a wall. Panels are produced in three thicknesses, 85mm, 100mm and 110mm, depending on acoustic rating (from 37dB-53dB).

Applications

The operable wall series is used wherever room space needs to be fully utilised. Hotels, conference centres, educational establishments, offices, training areas, etc. can all benefit from the flexibility of Dividers operable walls.

Operation

When the operable seals are retracted, panels glide effortlessly and quietly along the unique aluminium overhead track system (no need for floor guide).

Telescopic end panels enable the wall to be locked off to complete the acoustic seal. The track and carrier system provides ease of operation and directional flexibility, allowing panel stacking in countless configurations.

Finishes

For ultimate aesthetic appeal, panels can be supplied with practically any surface finish, including veneers, laminates, wall coverings, carpet, white board and decorative paintwork.



Operable Walls

Series 85, 100 & 110 Specification

Track details

Type 85

Single Point Track. Trim 6+7.

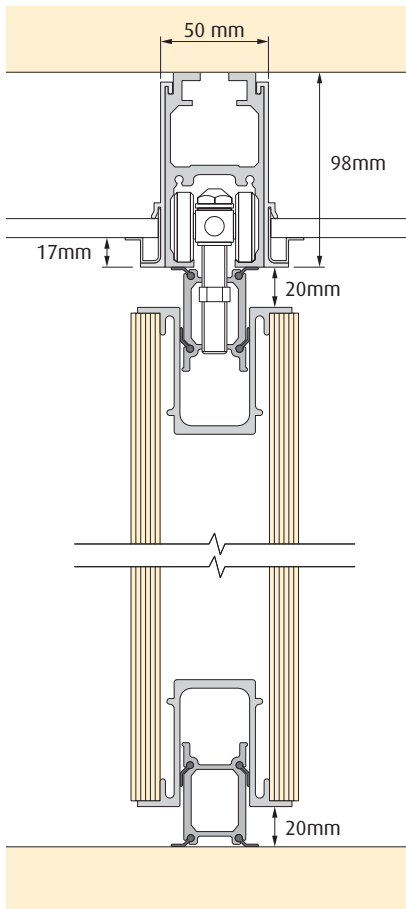

Type 100

Single Point Track. Trim 6+7.

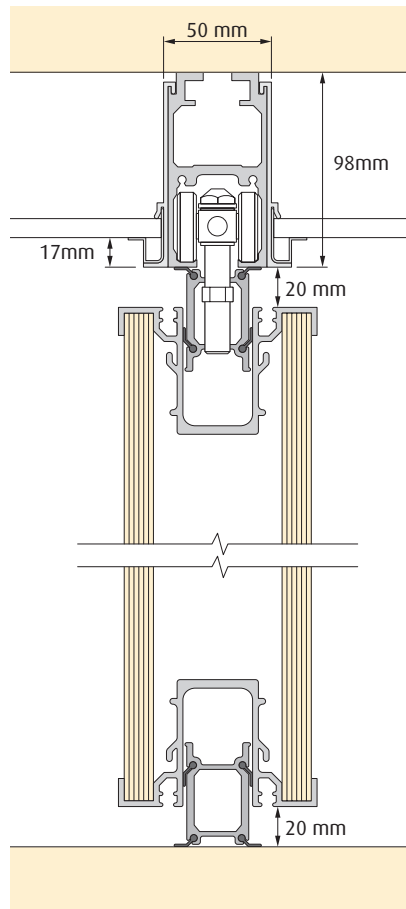

Type 110

Single Point Track. Trim 6+7.

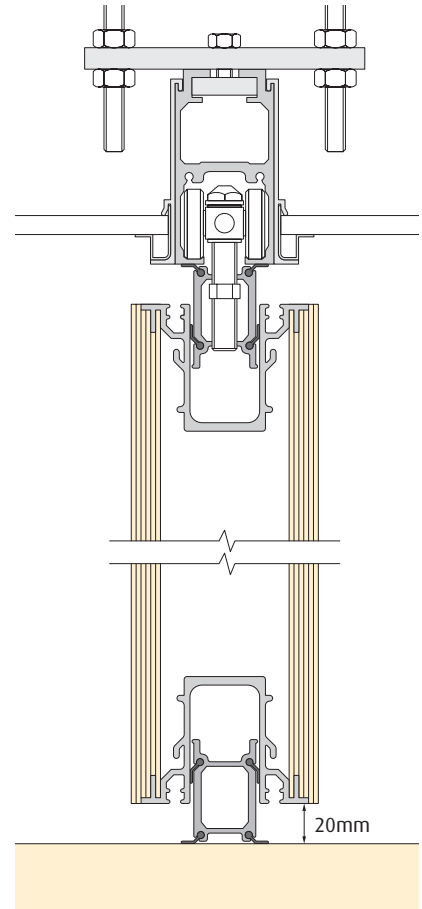

Steel programmable track system.

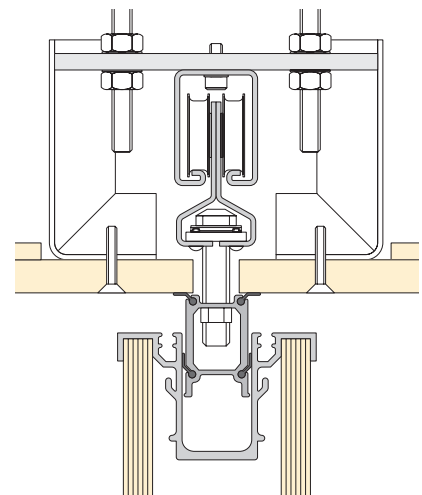

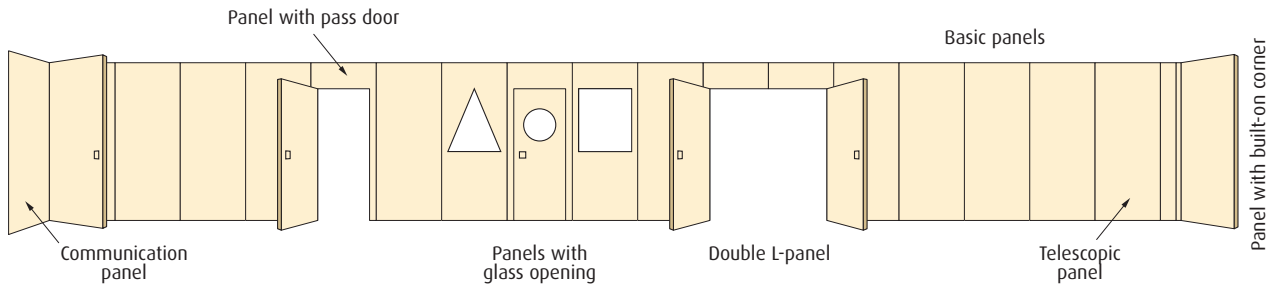

Panel Stacking Options

Centre

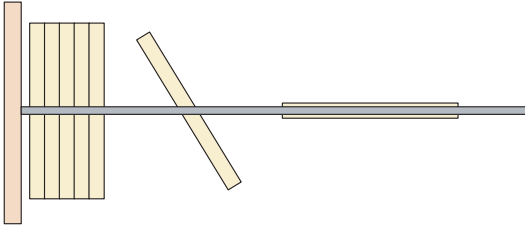

90° Side stack

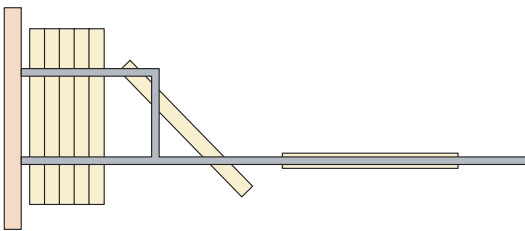

Remote stack

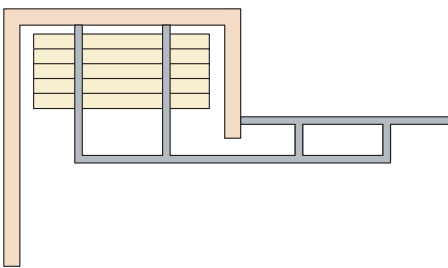

Twin 90° side stack

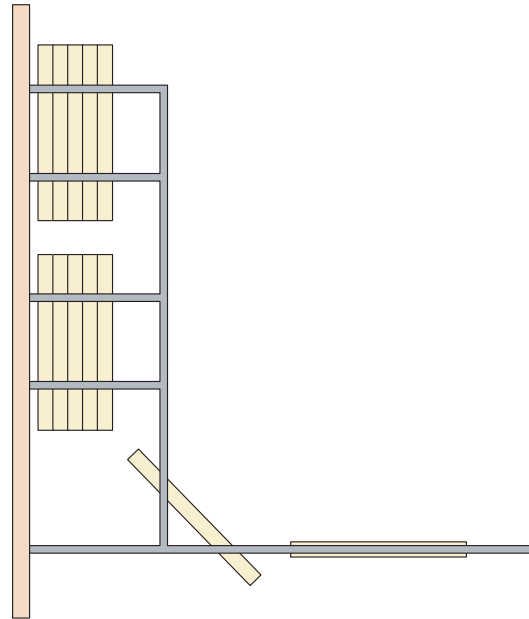

Recessed 90° side stack

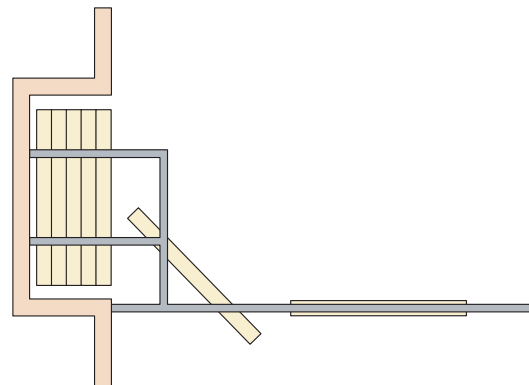



Key Features & Benefits

- Hinged Panels for quick and easy operation
- Robust aluminium frame construction for demanding environments
- Wide range of surface finishes
- Ceiling or floor mounted to accommodate most building designs
- End pass door incorporated enabling access to adjoining rooms
- Partial and fully glazed panels available

Folding Walls

Sesam Series 65 & 85

Sesam Vikett

The Sesam Vikett is a range of folding wall systems that incorporates a series of flat panels (each up to 900mm wide) that are hinged together to give a flush appearance when closed. The panels are manoeuvred on either a ceiling mounted track or an ultra low profile floor track system.

Sesam walls are quick to operate and are available in a range of acoustic ratings from 30dB – 49dB. Sound attenuation is achieved by modern manufacturing methods and the unique panel construction that consists of an aluminum frame, particleboard cladding and multiple acoustic infills.

Applications

The Sesam range is ideal for applications where the operation of the wall needs to be quick and easy and where a flush, flat wall appearance is desirable. The Sesam range is utilised extensively in educational establishments, offices, religious buildings and training areas.

Operation

The hinged panels incorporate fixed top and bottom sweep seals, which enable the operator to simply manoeuvre the partition into position in one easy action. Each wall section incorporates an end pass door panel, which provides a quick method of closing off the wall and also a means of access into adjoining rooms. The system can be top hung or floor mounted, which is particularly useful when the design of a building precludes any additional loading to the overhead structure.

Finishes

As with operable walls, the Sesam folding wall systems can be supplied in an almost endless choice of finishes, including veneers, laminates, wall coverings and fabrics. There is also the option of standard, or flush mounted hardware for the door panels.

Options

Partially or fully glazed panels, ceiling or floor track, choice of hardware.



Folding Walls

Sesam Series 65 & 85 Specification

Track options

Floor Mounted

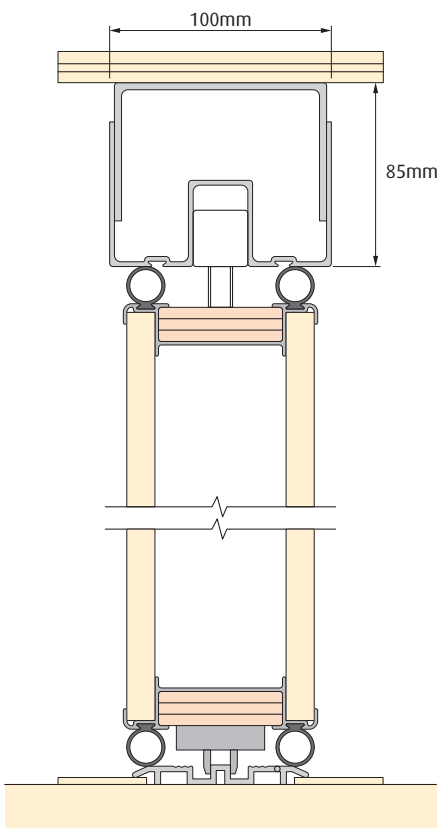

Top Hung

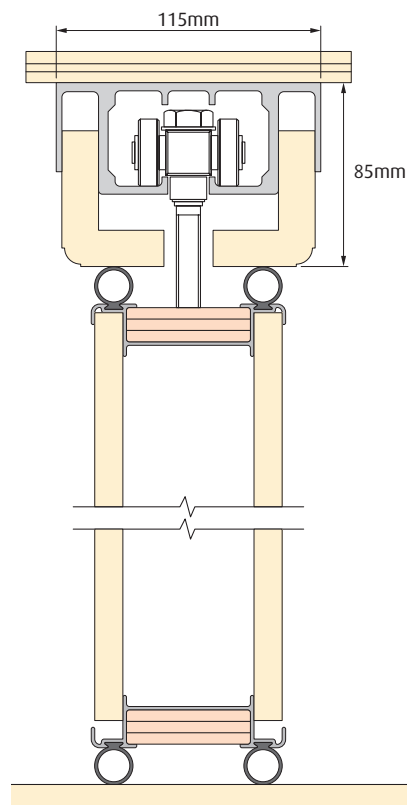

Horizontal Section

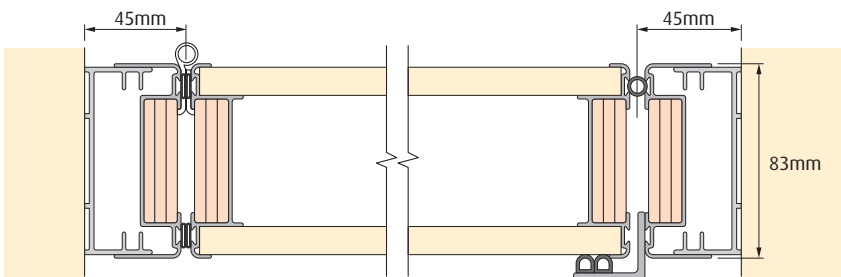

Low Profile Floor Track

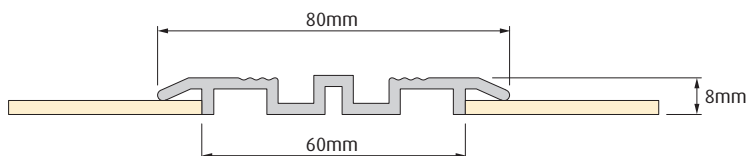

Stacking Options

Centre Folding

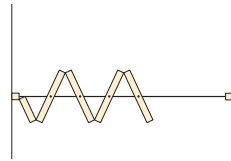

Eccentric Folding

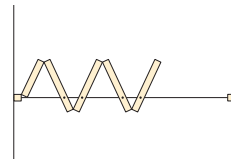

End Folding

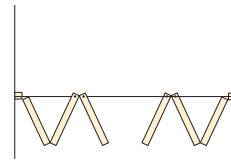

Model 85 panel weight

38	25 kg/m ²
41	30 kg/m ²
44	35 kg/m ²
46	40 kg/m ²
49	45 kg/m ²

Expanding Walls

Concertina Series 800, 801 & 160

Dividers Concertina

The Dividers range of expanding wall partitions are the key to flexible space utilisation. Whether in schools, hotels, community buildings or leisure centres, the Dividers expanding wall partition provides simple and cost effective solutions to space planning challenges, wherever space is at a premium.

The Dividers systems are track-operated, accordion-type partitions, based upon a pantographic steel frame, covered with vinyl-coated fabric as standard, or optional high-quality carpeted finish.

Applications

All systems can be supplied for openings of unlimited width on straight or curved track. Special lead posts are available to provide for cross, 'T' and 'L' junctions.

All installations are made to measure for specific applications and Dividers offer a complete design and installation service.

Operation

Both systems can be used as single units, or in pairs, operating with standard No.8 Aluminium track, recessed or surface-mounted.

For installations where sound reduction is a consideration, the 801 partition system gives sound reduction levels of an average 18.4dB; the 160 Soundmaster, an average of 31.2dB.

Finishes

Vinyl-coated partitions are available in a choice of nine modern colourways and are durable and easy to clean. A limited range of colours is also available in a special pvc-coated glass fibre fabric, offering a Class 1 fire rating when tested to BS 476 Part 7.

The textured Carpetfold finish is available in a range of eleven colourways to suit all styles of decor, again with the option of a special treatment for fire retardancy.

A tie back strap is fitted as standard on the 801 and 160 Series to retain the doors in the stacked position.

Options

Silver anodised handles and latch lock are fitted as standard. Latch lock with keys can be fitted to special order. Fixed handles are fitted to complement lock handles on pairs of partitions. A pendant pull is fitted to partitions over 2800mm high and/or 4600mm wide on single leaf partitions.



Vinyl colours available.

Our colour chart is available on request.





Key Features & Benefits

- Concertina construction for quick and easy operation
- Robust steel frame construction for demanding environments
- available in PVC fabric or carpet finish
- Ceiling mounted with no floor track on threshold
- Quick and easy to install

Expanding Walls Concertina Series 800, 801 & 160 Specification

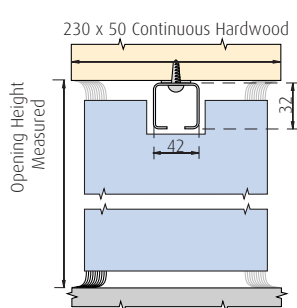

No. 8 Standard Track-Exposed

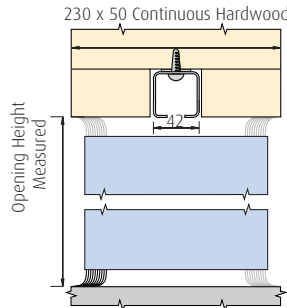

No. 8 Standard Track-Recessed

Maintenance

The durable vinyl covering can be cleaned using household soap and warm water; detergents must not be used for cleaning.

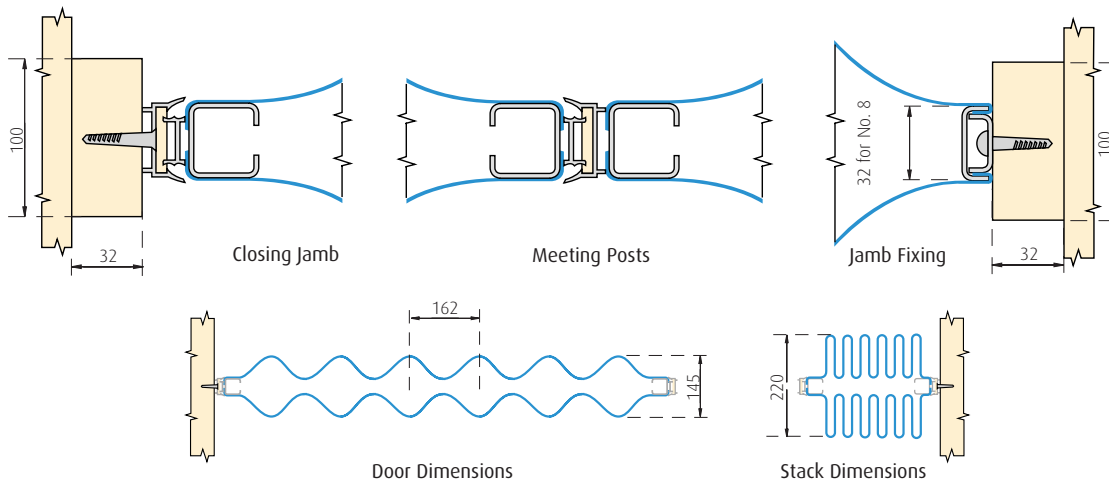

Compressed Stack Dimensions

Opening Width	No. 8 Trolleys Straight & Curved Doors	Opening Width	No. 8 Trolleys Straight & Curved Doors	Opening Width	No. 8 Trolleys Straight & Curved Doors
1041	275	4115	728	7188	1180
1219	299	4267	751	7366	1204
1372	323	4420	775	7518	1228
1524	347	4572	799	7671	1252
1676	371	4750	823	7849	1275
1854	395	4928	847	8001	1299
2007	418	5080	871	8179	1323
2184	442	5258	895	8357	1347
2337	466	5410	918	8534	1370
2489	490	5563	942	8686	1395
2667	514	5740	966	8839	1418
2819	537	5918	990	8991	1442
2997	561	6096	1014	9144	1466
3175	585	6248	1037	9296	1490
3353	609	6401	1061	9448	1514
3505	633	6553	1084	9601	1537
3658	656	6706	1109	9753	1561
3810	680	6858	1133	9956	1585
3962	704	7010	1156	10109	1609

All measurements in mm. For doors with intermediate post add 51mm to stack. To determine free stack add 1/6 to compressed stack dimension.

Folding Walls Uno & Duplo

Uno & Duplo

These folding walls are timber based, consisting of narrow strips of particleboard joined by continuous pvc strip hinges. the Uno is a single skinned partition, while the Duplo is double walled to provide enhanced acoustics and greater stability.

Applications

The Uno and Duplo are used in applications as diverse as hotels and hospitals. They are easy and quick to operate and can be manufactured in a wide range of finishes. In fact, anything that can be applied to particleboard.

Operation

The hinge system allows the wall to be operated quickly and easily in one operation. Sweep seals top and bottom ensure sound attenuation of between 28dB (Uno) and 43dB (Duplo).

Finishes

The Uno and Duplo can be manufactured in a wide range of finishes including veneers, laminates, wall coverings and decorative paint finishes.



Uno

Horizontal Section

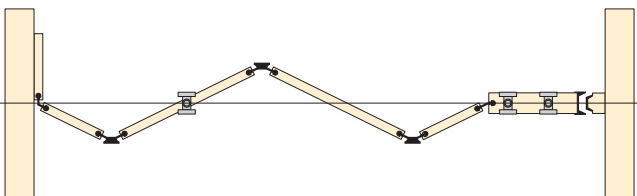

Standard Track

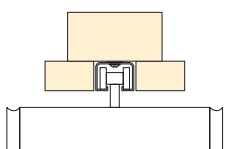

Track with Acoustic seal

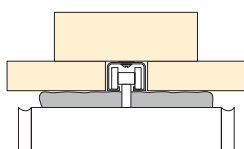

Duplo

Horizontal Section

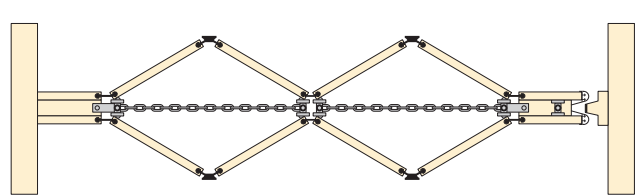

Track detail

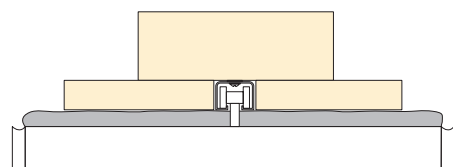



Movable Glass Partitions MGP

MGP

Applications

The MGP system provides the perfect solution for storefronts, restaurants and office environments where transparent space utilisation is the key requirement. It comprises of toughened glass panels secured in top and bottom profile elements which glide smoothly along an overhead track system.

The MGP system is available in moveable, folding, fixed and sliding glass walls configurations.

Operation

Stacking areas can be incorporated to enable panels to be stored away when the space needs to be opened up for access.

There are no floor tracks or guides ensuring a clear threshold, free of dirt traps and obstructions.

Doors can be incorporated at virtually any point along the partition and can be either single or double acting.

The unique locking mechanism ensures that there is minimal hardware used, ensuring a smooth panel appearance.

The system is fully secured by either mechanical or electrically operated locking mechanisms.

The Aluminium T-10 rail system with curve crossings and coated ball-bearing train gearing mechanisms guarantee excellent movability of wall and door elements. Curve crossings guarantee that even high elements are light and easy to move.

Finishes

Aluminium frame profile finished in:

- Brass coating
- Anodised
- Powder coated paint
- Decoral decorative coating

Glass

- Tempered safety glass 10 - 12 mm
- Tempered / laminated 5 + 5 mm

Treatment of glass

- Bright, bronze or grey
- Coloured lamination film
- Sandblasted
- Silk screen



Track Detail

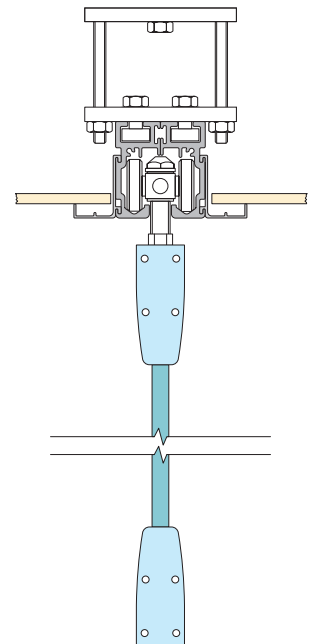



Operable Partitions and Folding Walls



DIVIDERS

DIVIDERS MODERNFOLD LIMITED

Factory and Head Office

Unit 1
Llanelli Gate
Dafen, Llanelli
SA14 8LQ

t: 01554 754510
f: 01554 741863

Northern Regional Office

Great Gutter Lane
Willerby, Hull
East Yorkshire
HU10 6BS

t: 01482 672933
f: 01482 672932

e: sales@dividersmodernfold.com
w: www.dividersmodernfold.com



A member of the Envirohold Group.



Whilst Dividers have taken every care to ensure the accuracy of the information, data or advice contained in this brochure, no liability in respect of such information or advice whether given negligently or not, can be accepted by the company. Dividers retain the right to amend the technical specifications of any range of walls, finishes and colours shown without prior notice